

ECLIPSE AIR HEAT BURNERS

Dimensions—Series "TAH-O"

Data 144-2

11/93

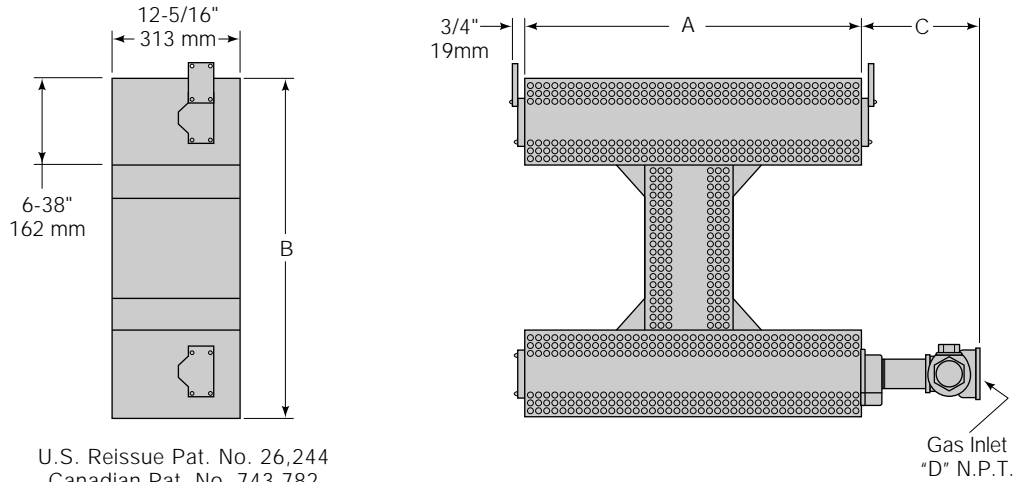

English Units

Burner Cat. No.	Assy. No.	Total Input MM Btu/Hr.		Dimensions In Inches				Cross Sect. Area Sq. In.	Approx. Ship Wt. Lbs.
		0.8 MM Btu/Ft.	1.0 MM Btu/Ft.	A	B	C	D		
240 TAH-O	109477	2.4	3.0	12-1/8	18-7/8	7-1/16	2	230	121
280 TAH-O	109478	2.8	3.5	12-1/8	24-7/8	7-15/16	2	269	138
320 TAH-O	109479	3.2	4.0	12-1/8	30-7/8	7-15/16	2	307	159
360 TAH-O	109480	3.6	4.5	12-1/8	36-7/8	7-15/16	2	345	179
400 TAH-O	109481	4.0	5.0	24-1/8	18-7/8	7-15/16	2	383	201
440 TAH-O	109482	4.4	5.5	24-1/8	24-7/8	9-5/16	3	422	219
480 TAH-O	109483	4.8	6.0	24-1/8	30-7/8	9-5/16	3	460	243
520 TAH-O	109484	5.2	6.5	24-1/8	36-7/8	9-5/16	3	498	274
560 TAH-O	109485	5.6	7.0	36-1/8	18-7/8	9-5/16	3	536	306
600 TAH-O	109486	6.0	7.5	36-1/8	24-7/8	9-5/16	3	575	339
640 TAH-O	109487	6.4	8.0	36-1/8	30-7/8	9-5/16	3	613	354
680 TAH-O	109488	6.8	8.5	36-1/8	36-7/8	9-5/16	3	651	380
720 TAH-O	109489	7.2	9.0	36-1/8	42-7/8	9-5/16	3	689	405

Metric Units

Burner Cat. No.	Assy. No.	Total Input kW		Dimensions In Millimeters				Cross Sect. Area Sq. Cm.	Approx. Ship Wt. Kgs.
		769 kW/M	962 kW/M	A	B	C	D		
240 TAH-O	109477	703	879	308	479	179	2"	1484	55
280 TAH-O	109478	821	1026	308	632	202	2"	1736	63
320 TAH-O	109479	938	1172	308	784	202	2"	1981	72
360 TAH-O	109480	1055	1319	308	937	202	2"	2226	81
400 TAH-O	109481	1172	1466	613	479	202	2"	2471	91
440 TAH-O	109482	1290	1612	613	632	237	3"	2723	99
480 TAH-O	109483	1407	1759	613	784	237	3"	2968	110
520 TAH-O	109484	1524	1905	613	937	237	3"	3213	124
560 TAH-O	109485	1641	2052	918	479	237	3"	3458	139
600 TAH-O	109486	1759	2198	918	632	237	3"	3710	154
640 TAH-O	109487	1876	2345	918	784	237	3"	3955	161
680 TAH-O	109488	1993	2491	918	937	237	3"	4200	172
720 TAH-O	109489	2110	2638	918	1089	237	3"	4445	184



ECLIPSE COMBUSTION, INC.

Pilot Components & Dimensions

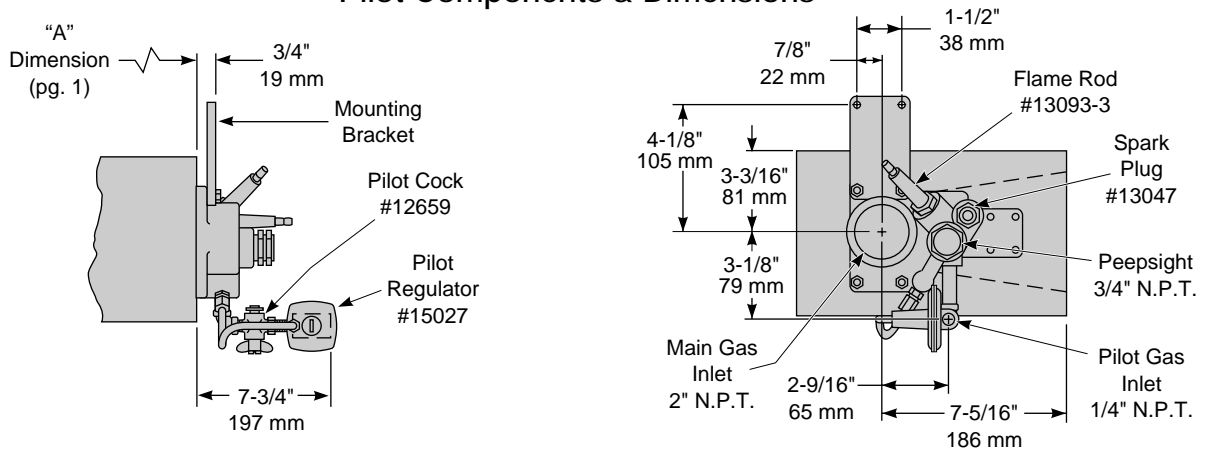

Check Valve Assembly Numbers

Burner	Assy.	N.P.T.
240 TAH-O	550096	1"
280 thru 400 TAH-O	550100	1-1/4"
440 thru 720 TAH-O	550104	1-1/2"



ECLIPSE COMBUSTION, INC.